

Little Nomad

Construction: Aluminium

This project was developed
in a partnership with



Sail Area
Recreational = 3.3 m²
Lifeboat = 2.3 m²

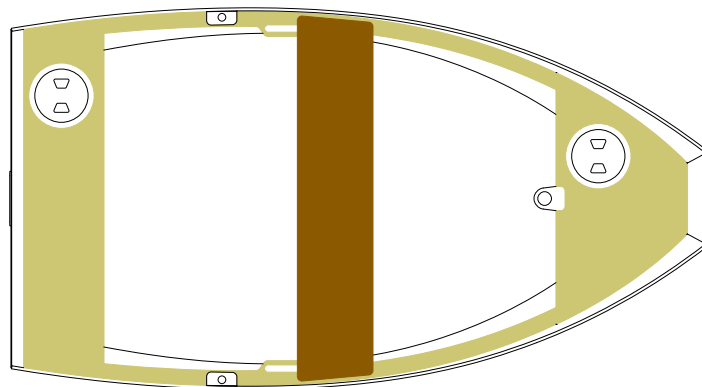

MAIN PARTICULARS:

LOA = 2.30 m	Min. Draught = 0.22 m
LWL = 1.95 m	Max. Draught = 0.75 m
BREADTH = 1.25 m	Displacement = 225 kg

Little Nomad

This project was developed
in a partnership with

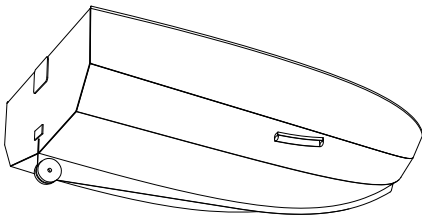
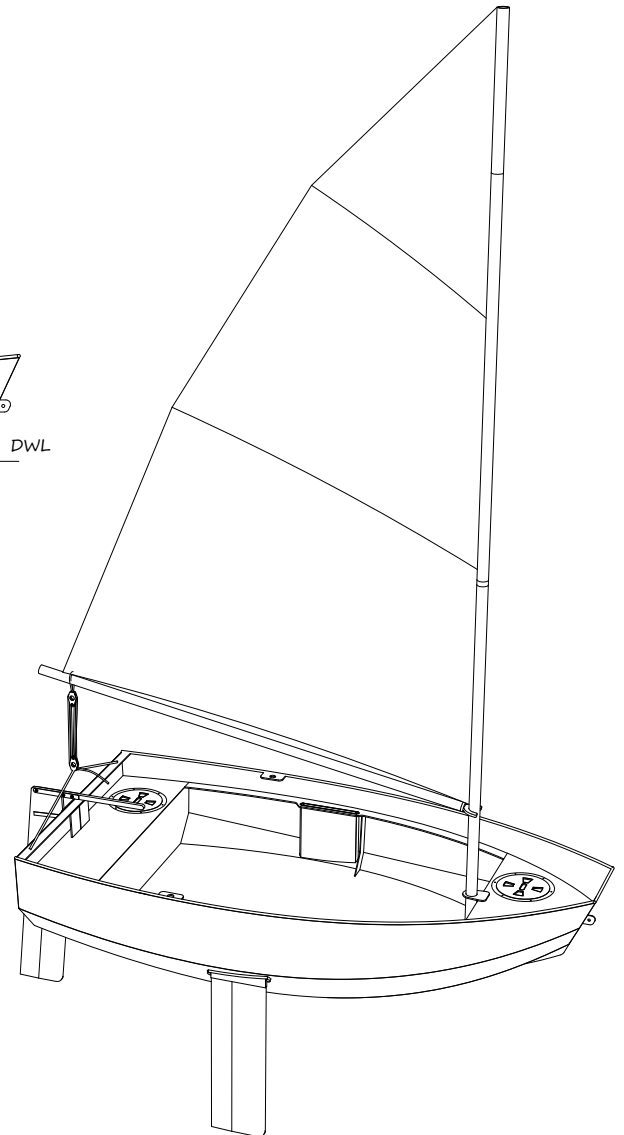
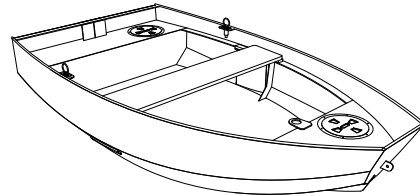

Construction: Alumium

MAIN PARTICULARS:

LOA = 2.30 m	Min. Draught = 0.22 m
LWL = 1.95 m	Max. Draught = 0.75 m
BREADTH = 1.25 m	Displacement = 225 kg